

## Waste Drums



Various Colours Available

### PRODUCT DESCRIPTION

Multi purpose drum used in sanitation market. Primarily used for chemical toilets for easy removal and transport

CODE	DESCRIPTION
2805AP	120Lt Waste drum c/w clamp
2806AP	125Lt Waste drum c/w clamp, lid & seal

CODE	LENGTH	DIAMETER	HEIGHT	WEIGHT
2805AP	n/a	608mm	570mm	5.0kg
2806AP	n/a	570mm	540mm	5.0kg

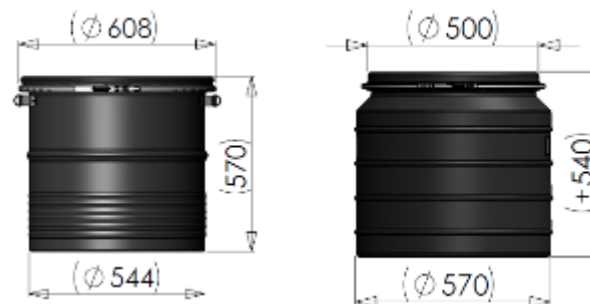

© Copyright in all drawings vests in Atlas Plastics (Pty) Ltd and may not be copied or disseminated in any manner without the consent of the copyright holder.

BACK

HOME

## Romeg Drum



Various Colours Available

### PRODUCT DESCRIPTION

A versatile range of storage drums for various uses. They all have a lid and lockable clamp

CODE	DESCRIPTION
342AP	50Lt Drum
872AP	100Lt Drum
874AP	210Lt Drum

CODE	LENGTH	DIAMETER	HEIGHT	WEIGHT
342AP	n/a	370mm	626mm	2.65kg
872AP	n/a	420mm	740mm	3.5kg
874AP	n/a	600mm	990mm	7.0kg

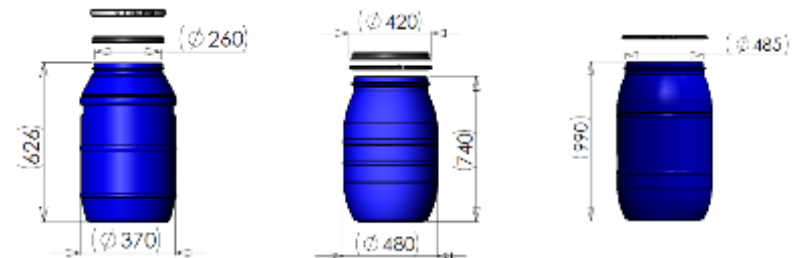

© Copyright in all drawings vests in Atlas Plastics (Pty) Ltd and may not be copied or disseminated in any manner without the consent of the copyright holder.

[HOME](#)

## 210Lt Stacking Open-head Drum



### PRODUCT DESCRIPTION

A versatile storage drum for various uses. They all have a lid and lockable clamp and can be stacked up to 5 units or more saving on transport costs

CODE	DESCRIPTION
871AP	210Lt Drum

CODE	LENGTH	DIAMETER	HEIGHT	WEIGHT
871AP	n/a	614mm	1008mm	7.25kg

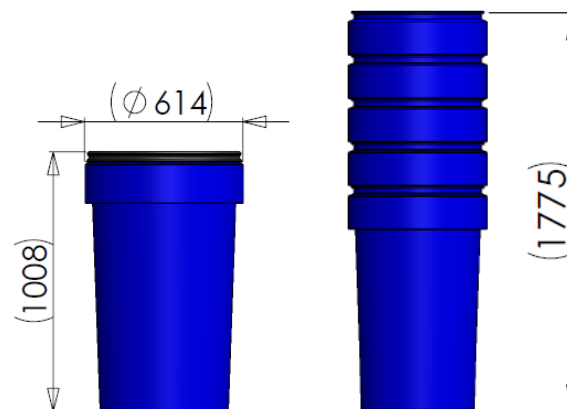

© Copyright in all drawings vests in Atlas Plastics (Pty) Ltd and may not be copied or disseminated in any manner without the consent of the copyright holder.

[HOME](#)

## Triangular Bucket



### PRODUCT DESCRIPTION

The toughest buckets for use on construction sites or general use

CODE	DESCRIPTION
298AP	15lt Builders bucket - Triangular economy
301AP	15lt Builders bucket - Triangular

CODE	WIDTH	LENGTH	HEIGHT	WEIGHT
298AP	350mm	344mm	270mm	0.7kg
301AP	350mm	344mm	270mm	1.1kg

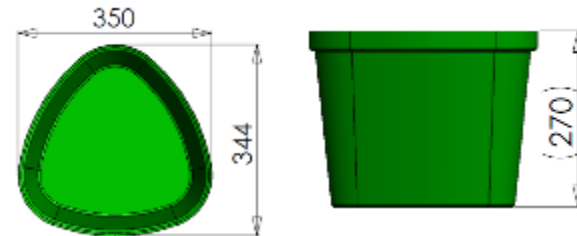

© Copyright in all drawings vests in Atlas Plastics (Pty) Ltd and may not be copied or disseminated in any manner without the consent of the copyright holder.

[BACK](#) [HOME](#)

## Round Bucket



Various Colours Available

### PRODUCT DESCRIPTION

The toughest buckets for use on construction sites or general use

CODE	DESCRIPTION
299AP	12lt Builders bucket - Round economy
302AP	12lt Builders bucket – Round
300AP	4.5lt Milk Bucket

CODE	LENGTH	DIAMETER	HEIGHT	WEIGHT
299AP	n/a	314mm	255mm	0.7kg
302AP	n/a	314mm	255mm	1.0kg
300AP	230mm	158mm	210mm	0.5kg

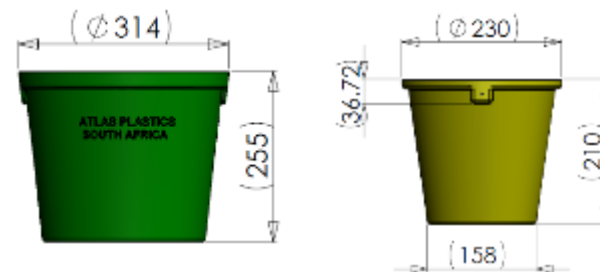

© Copyright in all drawings vests in Atlas Plastics (Pty) Ltd and may not be copied or disseminated in any manner without the consent of the copyright holder.

[HOME](#)

## 20Lt Pail



Various Colours Available

### PRODUCT DESCRIPTION

A tough durable 20Lt pail

CODE	DESCRIPTION
150AP	20lt Pail c/w galvanized handle
213AP	20Lt Pail

CODE	TOP DIA	BOTTOM DIA	HEIGHT	WEIGHT
150AP	375mm	258mm	350mm	1.6kg
213AP	375mm	258mm	350mm	1.6kg

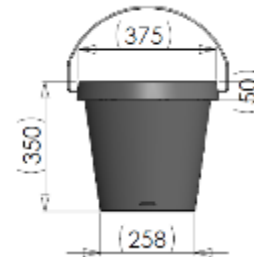

© Copyright in all drawings vests in Atlas Plastics (Pty) Ltd and may not be copied or disseminated in any manner without the consent of the copyright holder.

[HOME](#)